

LAB 12

Owner's Manual

dac1 *reference*

Handcrafted Digital to Analog Converter

www.lab12.gr

v1.3

LAB 12

K. Varnali 57A, Metamorfosi,

14452, Athens, Greece

Tel: +30 210 2845173

Email: contact@lab12.gr

Web: www.lab12.gr

Table of Contents

It is yours.....	4
Unpacking and Warnings.....	4
Features.....	5
Installation & Placement.....	5
Front Panel Indicators.....	6
Rear Panel Connections.....	7
Main Connections.....	8
For the safety of your equipment.....	9
Specifications.....	9

IT IS YOURS!

Thank you for selecting Lab12 handcrafted Digital to Analog Converter (DAC). Every component on it is designed to provide smooth and untreated sound. Pure analogue sound with non oversampling conversion by 8 matched parallel Phillips TDA1543 in a sophisticated configuration and smooth output through a pair of Dual triode tubes I/V stage. All components are carefully chosen after hours of listening and testing, while paying great attention to every detail affecting the outcome. Ultra solid construction with glass blasting anodized finishing and retro analogue V/U meters.

Do not forget that your DAC is totally handcrafted with perfectly matched parts of the finest selections. In order to reach the optimal performance your dac1 reference needs at least 200 hours of listening. In this time all components go from “burn in” period to stable.

Before setting up your new dac1 reference, we encourage you to read this manual thoroughly to properly acquaint yourself with its features. We love music and audio devices and we have built your new device with emotion and personal treatment.

The information contained in this manual is subject to change without notice. The most current version of this manual is available on our official website at <http://www.lab12.gr>

Unpacking

Dac1 reference should be removed from its box with care. Remove all the foam protective pieces of the box before you unpack dac1 reference. Unpack dac1 reference with your hands on both sides of the device.

Warnings

No user serviceable parts are included inside. Do not unscrew the cover; high voltages remain after disconnecting from mains. In case your device requires any kind of service or upgrade, please ship or take your equipment directly to Lab12 or to one of our authorized dealers.

Always use same type of fuse for replacement.

Features

- Input Sampling Rate up to 24bit/192 kHz
- Non-Oversampling mode
- 8x Multibit Philips DACs network
- 2x Dual Triodes tubes I/V analog output stage
- 6 Separate Regulated Power Supplies
- Analog retro VU meters
- 6mm Aluminum face panel
- Five Years Guarantee

Installation & Placement

Lab12 dac1 reference should be placed on a solid flat surface. You should avoid placing it near a heat source as this could compromise the performance and reliability. You should never place another component directly on top of this device. Make sure that your dac1 reference has an adequate flow of air around it.

Dac1 reference could be warm in some points; this is normal and within parts' specifications. Take care of the front panel's glass blasting anodized finishing using a soft dry cloth. No need to use any sprays or polishes. Never use cleaners containing abrasives, as this will damage the surface.

Front Panel Indicators

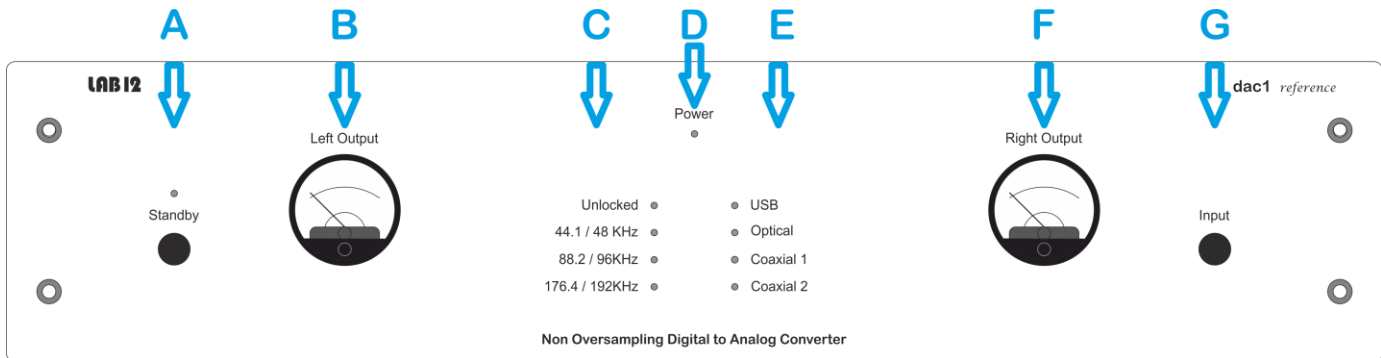

DAC1 Front panel

In the front panel you will see ten (10) indication LEDs, two VU meters, one Input selector push button and one Standby push button.

The center LED **(D)** indicates that the device is powered on, in working condition.

The 4 input LEDs **(E)** indicate the selected digital input. You can manually select the preferable input with the Input selector push button on the right of the front panel **(G)**.

The 4 status LEDs **(C)** indicate the locked sampling frequency rates of the input digital signal. The 'Unlocked' LED indicates that there is no digital signal on input or the sampling frequency of the digital signal is not compatible with dac1 reference.

On the left of the front panel, you will find the Standby push button and indication LED **(A)**. When active, it indicates that **dac1 reference** is in Standby Mode. You can leave the device in Standby Mode without the need to turn off the main power switch on the back panel.

To the left and right of the 8 center LEDs you will see two retro analog VU meters **(B & F)**. You can accurately monitor the output level of each channel on dB scale.

Rear Panel Connections

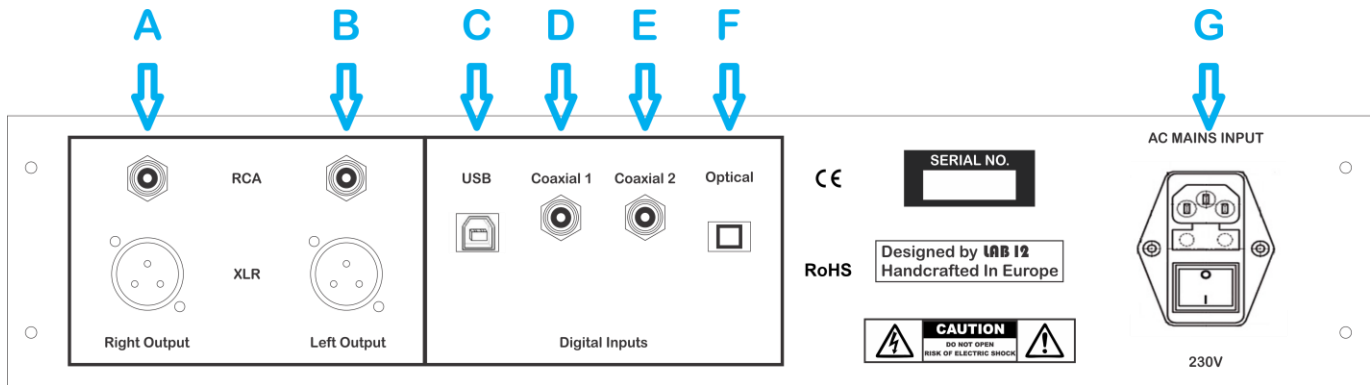

DAC1 Rear panel

In rear panel you will find the connection inputs and outputs.

On the left side, you will find a pair of single-ended RCA and a pair of unbalanced XLR (**A & B**) analog audio output connectors.

In the middle of rear panel, you will find the four digital inputs. You can connect directly a personal computer or streamer via USB2 input (**C**) or any other digital unit with SPDIF digital outputs on the two available coaxial inputs (**D & E**) or the Toslink optical (**F**).

To the right side of rear panel, you will find the **IEC AC input (G)**. Below IEC input, the main fuse holder and the main power switch are located (**G**).

Main connections

Connect a High-Grade Power cable to the IEC input and to your wall socket. Make sure that your wall socket provides a good ground before connecting the power cable. You can supply 230 to 240 AC Volts /50Hz (115 to 120 AC Volts / 60Hz). Every **dac1 reference** is calibrated and tested with the usage of a **Lab12 Knack mk2 power cable**. We strongly suggest using this cable.

Connect to your Preamplifier or Integrated Amplifier

Connect the analog output (RCA or XLR) to an analog line level input to your Preamplifier or Integrated Amplifier. Make sure about the correct channel connections. We suggest using an audio grade interconnect cable pair. You can choose between RCA and XLR connection.

Connect a Digital SPDIF Output Source

Make sure that your digital source has a SPDIF 75ohm coaxial or optical Toslink digital output. Connect the digital interconnect cable (or fibre optical) from the source output to the correspondence input of **dac1 reference**. Turn on your **dac1 reference** and then your digital source unit and activate the digital audio output on it (if needed). Select the desirable input with input select push button on dac1 reference. Dac1 reference can accept resolutions up to 192KHz and up to 24 Bit Depth on any digital input.

Use an audio grade digital 75-ohm digital interconnect cable to ensure the best transfer of your digital signal.

- ❖ Please note that Coaxial 2 must be always locked in lower sampling rate frequency than Coaxial 1.
- ❖ Please note that official specifications for Toslink SPDIF protocol (Optical Input), are limited to 96KHz/24bit. Depending on connection and source, optical input higher sampling rate could be limited.

Connect a PC

Connect dac1 reference to a USB2 or higher on your personal computer. Windows 7 or higher and IOS will automatically detect the official drivers for the USB receiver of dac1 reference. In other cases, you have to manually install drivers (you can find Windows and IOS drivers in our website). Please choose "Lab12 Dac1 reference" on output playback devices menu of your personal computer.

For the safety of your equipment

! Make sure that all your equipment is turned off before any connection.

! Please keep in mind that you have to turn on dac1 reference some seconds before turning on your amplifier and turn it off some seconds after turning off your amplifier.

Specifications

- Power: 210 - 240VAC 50Hz (110 - 120VAC 60Hz)
- Power consumption: 70 VA max
- Inputs: 2x SPDIF (Coaxial RCA), 1x USB2, 1x SPDIF (Optical Toslink)
- Outputs: 2x RCA, 2x XLR unbalanced (balanced version available)
- Frequency response: 20Hz to 20 KHz + 0dB/-1dB
- THD: lower than 0.15%
- Rated output level: 2.5Vrms
- Tube complement: 2x 6922 dual triode
- Available Colours: Matt Black, Frozen Silver
- Dimensions (WxHxD): 43x11x29 cm
- Weight: 7.5 Kg

Warranty

This device has 5 years warranty for all parts (or 90-Day Limited Warranty for vacuum tubes) from the day of purchase.

We wish you to enjoy your new device exactly as we enjoyed it when we built it for you!

LAB 12

Notes:

.....
.....
.....
.....
.....
.....

.....
.....
.....
.....
.....
.....

.....
.....
.....
.....
.....
.....

LAB 12

K. Varnali 57A, Metamorfofi,

14452, Athens, Greece

Tel: +30 210 2845173

Email: contact@lab12.gr

Web: www.lab12.gr